

S6E300-AS02-06

AC axial fan - HyBlade

sickle-shaped blades (S series), single-intake
with guard grille for short nozzle

Nominal data

Type	S6E300-AS02-06		
Motor	M6E068-CF		
Phase		1~	1~
Nominal voltage	VAC	230	230
Frequency	Hz	50	60
Method of obtaining data		ml	ml
Valid for approval/standard		CE	CE
Speed (rpm)	min ⁻¹	900	1020
Power consumption	W	30	36
Current draw	A	0.14	0.16
Capacitor	µF	1	1
Capacitor voltage	VDB	400	400
Capacitor standard		S0 (CE)	S0 (CE)
Max. back pressure	Pa	25	33
Max. back pressure	in. wg	0.1	0.13
Min. ambient temperature	°C	-40	-40
Max. ambient temperature	°C	55	60
Starting current	A	0.2	0.2

ml = Max. load · me = Max. efficiency · fa = Free air · cs = Customer specification · ce = Customer equipment
Subject to change

Low-temperature ball bearing

AC axial fan - HyBlade

sickle-shaped blades (S series), single-intake
with guard grille for short nozzle

Technical description

Weight	2.9 kg
Size	300 mm
Motor size	68
Rotor surface	Painted black
Terminal box material	PC/ABS plastic
Blade material	Press-fitted sheet steel blank, sprayed with PP plastic
Guard grille material	Steel, coated with pure-white plastic (RAL 9010)
Number of blades	5
Airflow direction	A
Direction of rotation	Clockwise, viewed toward rotor
Degree of protection	IP44; installation- and position-dependent
Insulation class	"F"
Moisture (F) / Environmental (H) protection class	H1+
Max. permitted ambient temp. for motor (transport/storage)	+ 70 °C
Min. permitted ambient temp. for motor (transport/storage)	- 40 °C
Installation position	Shaft horizontal or rotor on top; rotor on bottom on request
Condensation drainage holes	On stator side
Mode	S1
Motor mounting	Ball bearing with low-temperature lubricant
Touch current according to IEC 60990 (measuring circuit Fig. 4, TN system)	< 0.75 mA
Electrical hookup	Terminal box; Via terminal box, capacitor integrated and connected
Motor protection	Thermal overload protector (TOP) internally connected
With cable	Axial
Protection class	I (with customer connection of protective earth)
Motor capacitor according to EN 60252-1 in safety protection class	S0
Conformity with standards	EN 60335-1; CE

S6E300-AS02-06

AC axial fan - HyBlade

sickle-shaped blades (S series), single-intake
with guard grille for short nozzle

Product drawing

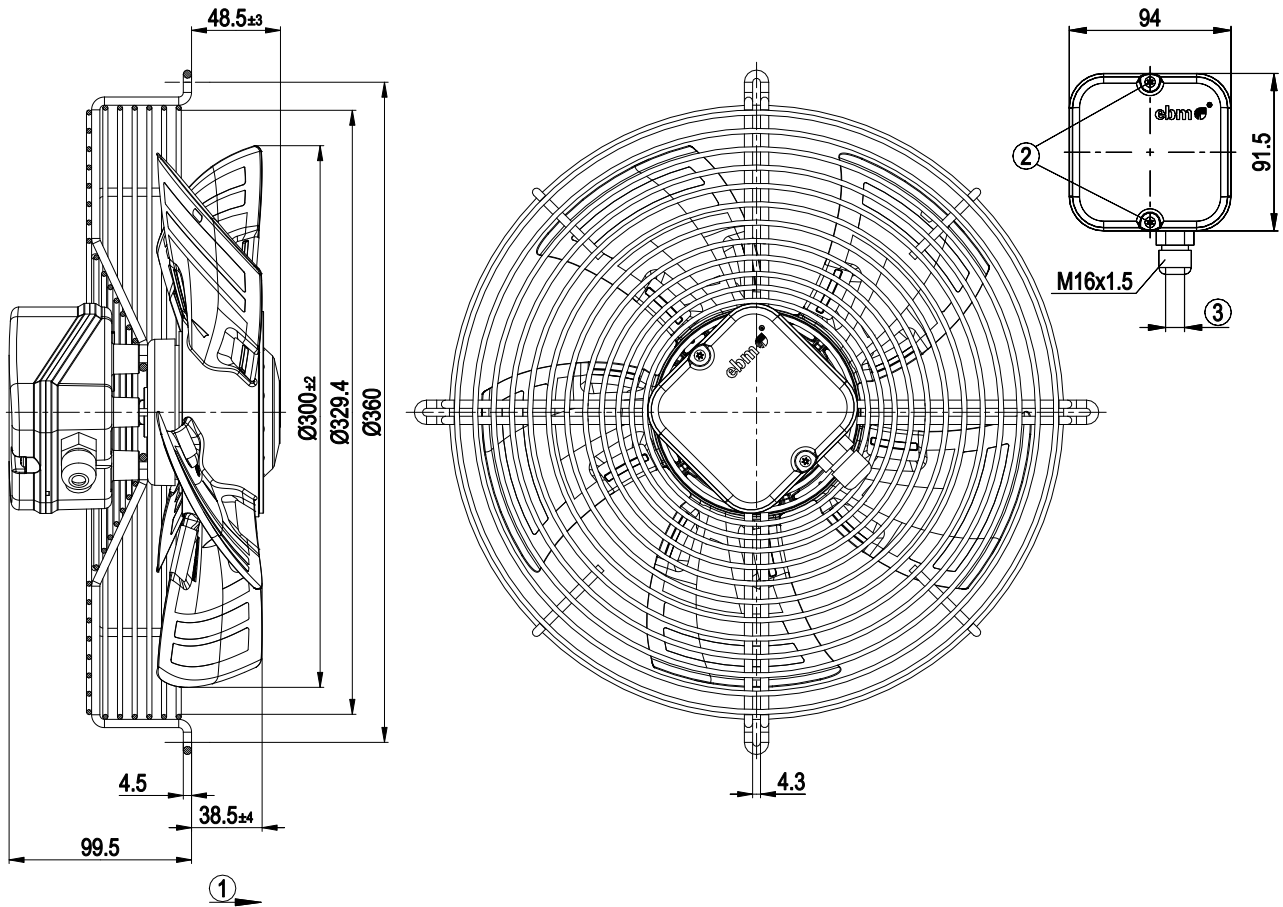

- | | |
|---|--|
| 1 | Direction of air flow "A" |
| 2 | Tightening torque 0.5 ± 0.1 Nm |
| 3 | Cable diameter max. 7.5 mm, tightening torque 1.3 ± 0.2 Nm |

Connection diagram

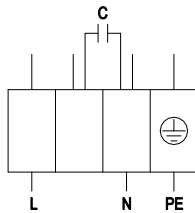

PE	green/yellow	L	black	N	blue
----	--------------	---	-------	---	------

AC axial fan - HyBlade

sickle-shaped blades (S series), single-intake
with guard grille for short nozzle

Curves: Air performance 50 Hz

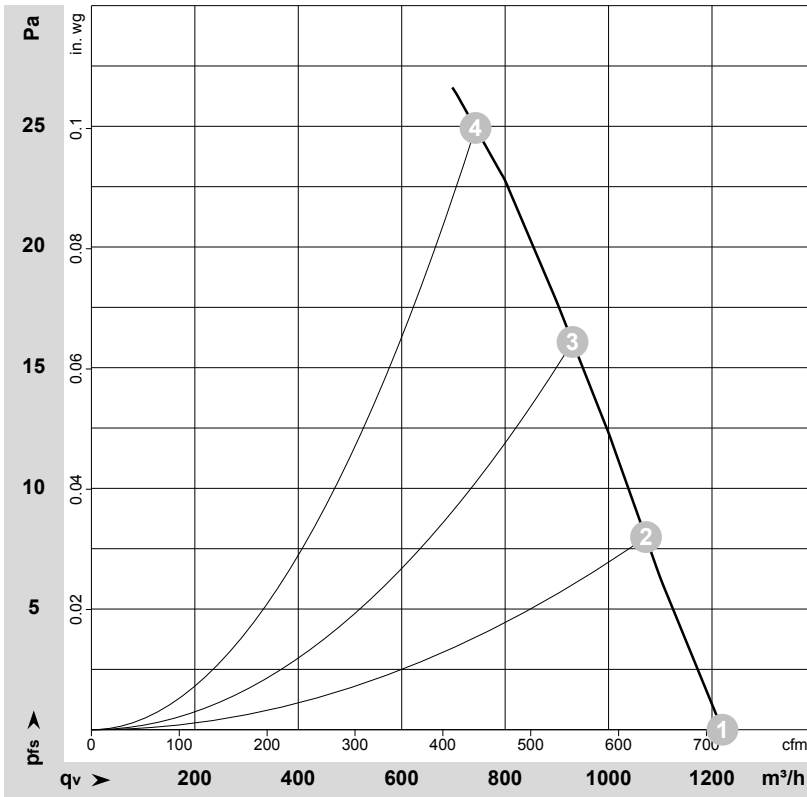

$\rho = 1.15 \text{ kg/m}^3 \pm 2 \%$

Measurement: LU-185731-1

Air performance measured according to ISO 5801 installation category A. For detailed information on the measurement setup, contact ebm-papst. Intake sound level: Sound power level according to ISO 13347 / sound pressure level measured at 1 m distance from fan axis. The values given are valid under the specified measuring conditions and may vary due to conditions of installation. For deviations from the standard configuration, the parameters have to be checked on the installed unit.

Measured values

	Wired	U	f	n	P _e	I	LpA _{in}	LwA _{in}	q _v	P _{fs}	q _v	P _{fs}
		V	Hz	min ⁻¹	W	A	dB(A)	dB(A)	m ³ /h	Pa	cfm	in. wg
1	1~	230	50	925	28	0.13	43	51	1220	0	720	0.00
2	1~	230	50	910	29	0.13	41	48	1070	8	630	0.03
3	1~	230	50	905	29	0.13	38	46	930	16	545	0.06
4	1~	230	50	900	30	0.14	36	45	745	25	435	0.10

Wired = Wiring · U = Power supply · f = Frequency · n = Speed (rpm) · P_e = Power consumption · I = Current draw · LpA_{in} = Sound pressure level intake side · LwA_{in} = Sound power level intake side
q_v = Air flow · P_{fs} = Pressure increase

AC axial fan - HyBlade

sickle-shaped blades (S series), single-intake
with guard grille for short nozzle

Curves: Air performance 60 Hz

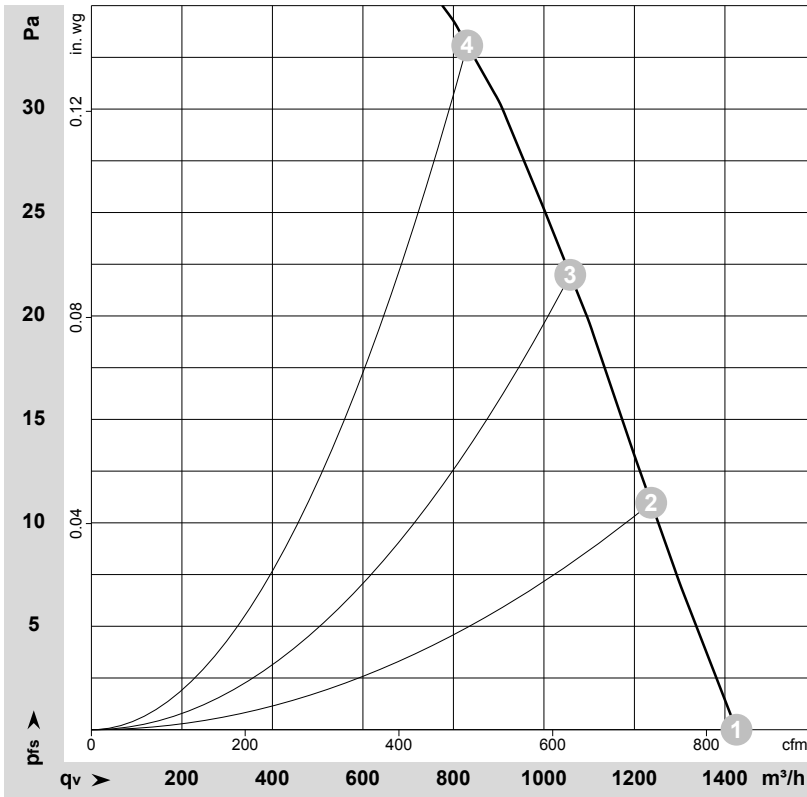

$\rho = 1.15 \text{ kg/m}^3 \pm 2 \%$

Measurement: LU-185738-1

Air performance measured according to ISO 5801 installation category A. For detailed information on the measurement setup, contact ebm-papst. Intake sound level: Sound power level according to ISO 13347 / sound pressure level measured at 1 m distance from fan axis. The values given are valid under the specified measuring conditions and may vary due to conditions of installation. For deviations from the standard configuration, the parameters have to be checked on the installed unit.

Measured values

	Wired	U	f	n	P _e	I	LpA _{in}	LwA _{in}	q _v	P _{fs}	q _v	P _{fs}
		V	Hz	min ⁻¹	W	A	dB(A)	dB(A)	m ³ /h	Pa	cfm	in. wg
1	1~	230	60	1080	33	0.15	49	55	1425	0	840	0.00
2	1~	230	60	1060	34	0.15	46	53	1235	11	730	0.04
3	1~	230	60	1040	35	0.15	43	51	1060	22	625	0.09
4	1~	230	60	1020	36	0.16	42	50	830	33	490	0.13

Wired = Wiring · U = Power supply · f = Frequency · n = Speed (rpm) · P_e = Power consumption · I = Current draw · LpA_{in} = Sound pressure level intake side · LwA_{in} = Sound power level intake side
q_v = Air flow · P_{fs} = Pressure increase