

Nominal data

Type	S4D500-AM01-03						
Motor	M4D110-GF						
Phase		3~	3~	3~	3~	3~	3~
Nominal voltage	VAC	230	230	277	400	400	480
Connection		Δ	Δ	Δ	Y	Y	Y
Frequency	Hz	50	60	60	50	60	60
Type of data definition		ml	ml	ml	ml	ml	ml
Valid for approval / standard		CE	CE	CE	CE	CE	CE
Speed	min ⁻¹	1350	1510	1590	1350	1510	1590
Power input	W	690	950	1050	690	950	1050
Current draw	A	2.34	2.77	2.72	1.35	1.6	1.57
Max. back pressure	Pa	155	145	160	155	145	160
Max. ambient temperature	°C	65	60	60	65	60	60

ml = max. load · me = max. efficiency · fa = running at free air · cs = customer specs · cu = customer unit
Subject to alterations

Data according to ErP directive

Installation category	A	Overall efficiency η_e	Actual	Request 2013	Request 2015
Efficiency category	Static	Efficiency grade N	33,3	28,5	32,5
Closed-loop speed control	No	Power input P_e	40,8	36	40
Specific ratio*	1,00	Power input P_e	kW	0,66	
		Air flow q_v	m ³ /h	5985	
		Pressure increase Total p_{sf}	Pa	134	
		Speed n	min ⁻¹	1355	

* Specific ratio = $1 + p_{sf} / 100\,000$

Data established at point of optimum efficiency

S4D500-AM01-03

AC axial fan - HyBlade®

sickled blades (S series)

with guard grille for short nozzle

Technical features

Mass	13 kg
Size	500 mm
Surface of rotor	Coated in black
Material of terminal box	PC/ABS plastic, black
Material of blades	Press-fitted sheet steel blank, sprayed with PP plastic
Material of guard grille	Steel, phosphated and coated in black plastic
Number of blades	5
Direction of air flow	"V"
Direction of rotation	Counter-clockwise, seen on rotor
Type of protection	IP 54
Insulation class	"F"
Humidity class	F4-1
Max. permissible ambient motor temp. (transp./ storage)	+ 80 °C
Min. permissible ambient motor temp. (transp./storage)	- 40 °C
Mounting position	Shaft horizontal or rotor on bottom; rotor on top on request
Condensate discharge holes	Rotor-side
Operation mode	S1
Motor bearing	Ball bearing
Leakage current	<= 3.5 mA
Electrical leads	Via terminal box
Motor protection	Thermal overload protector (TOP) brought out
Cable exit	Axial
Protection class	I (if protective earth is connected by customer)
Product conforming to standard	EN 61800-5-1; CE
Approval	VDE; UL 1004-1; CSA C22.2 Nr.100; CCC

S4D500-AM01-03

AC axial fan - HyBlade®

sickled blades (S series)

with guard grille for short nozzle

Product drawing

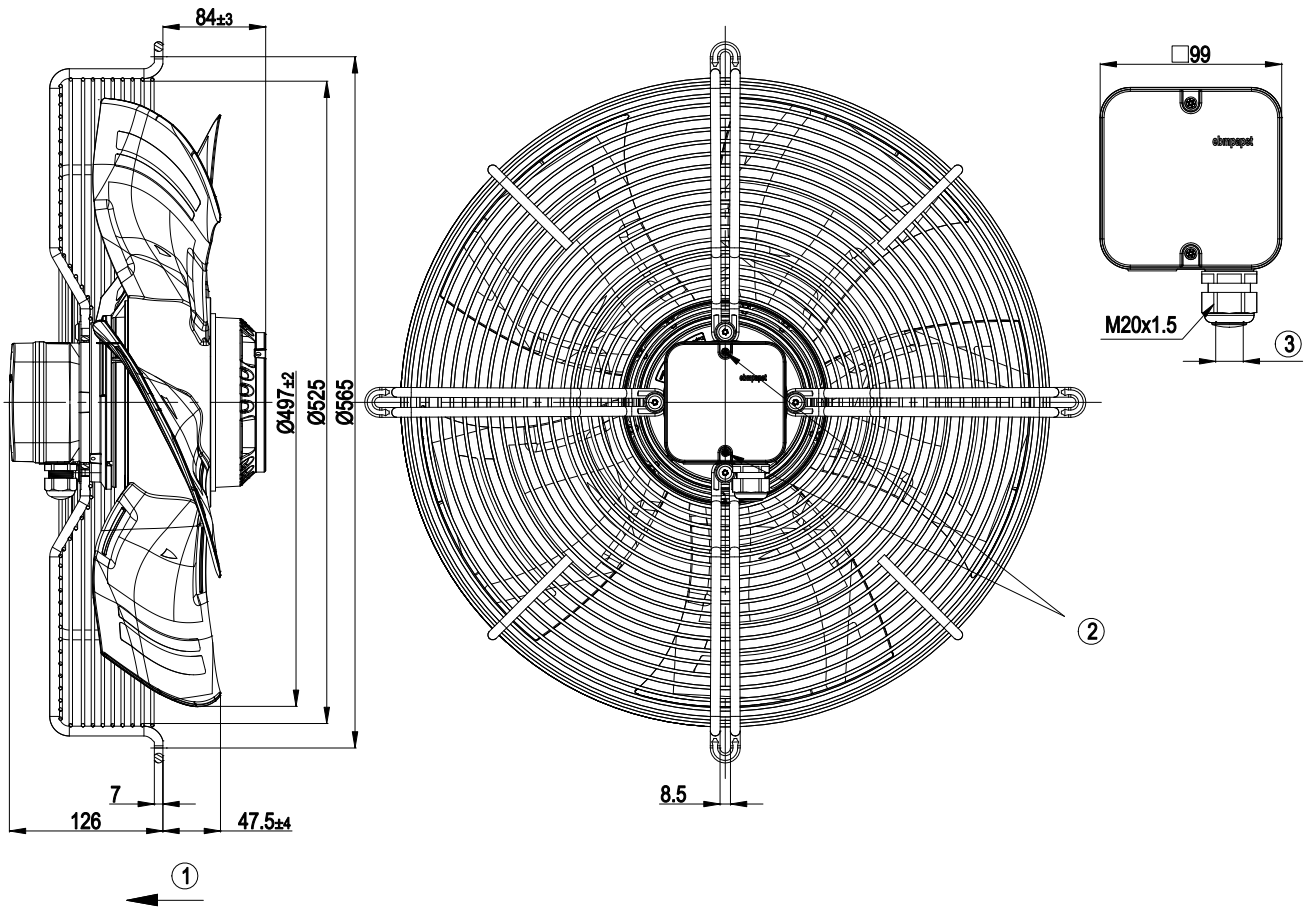

1	Direction of air flow "V"
2	Tightening torque 1.5 ± 0.2 Nm
4	Cable diameter: min. 6 mm, max. 12 mm, tightening torque: 2 ± 0.3 Nm

S4D500-AM01-03

AC axial fan - HyBlade®

sickled blades (S series)

with guard grille for short nozzle

Connection screen

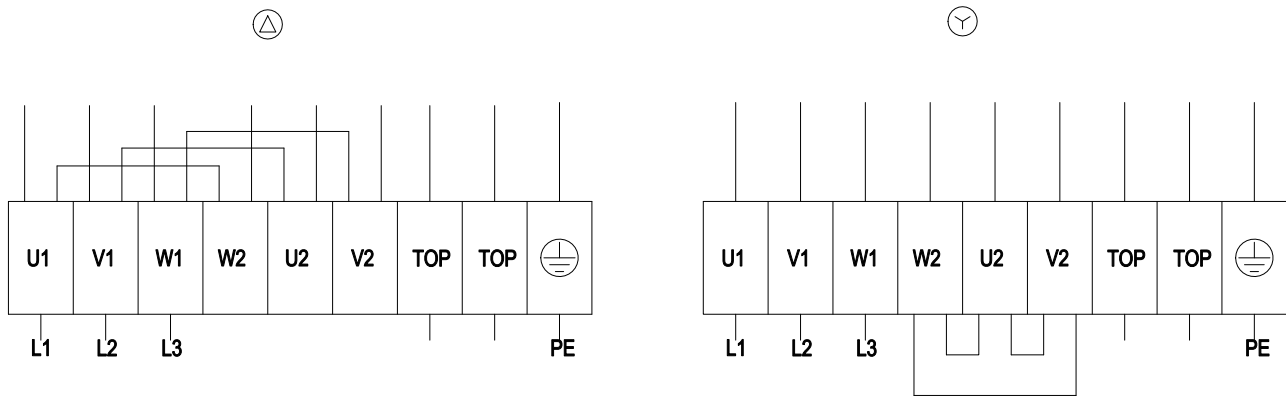

Note: Direction of rotation changes when two phases are reversed

Δ	Delta-connection	Y	Star connection	L1	= U1 = black
L2	= V1 = blue	L3	= W1 = brown	W2	yellow
U2	green	V2	white	TOP	2 x grey
PE	green / yellow				

Charts: Air flow 50 Hz

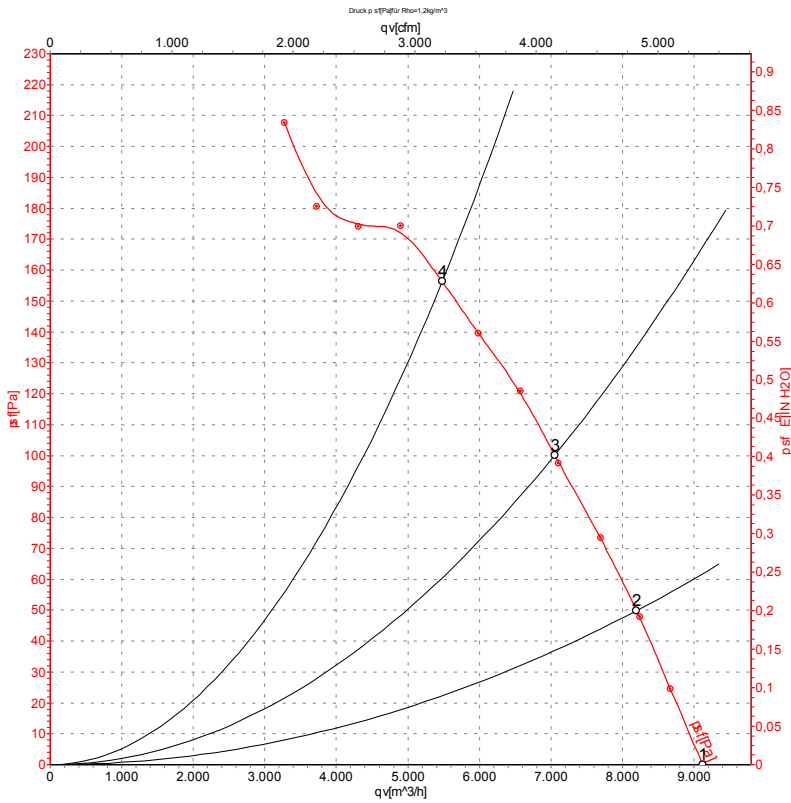

Measurement: LU-110665

Air performance measured as per ISO 5801 Installation category A. For detailed information on the measuring set-up, please contact ebm-papst. Suction-side noise levels: LwA measured as per ISO 13347 / LpA measured with 1m distance to fan axis. The values given are valid under the measuring conditions mentioned above and may vary according to the actual installation situation. With any deviation from the standard set-up, the specific values have to be checked and reviewed with the unit installed.

Measured values

	Conn.	U	f	n	P _e	I	LpA _{in}	LwA _{in}	LwA _{out}	qv	p _{sf}
		V	Hz	min ⁻¹	W	A	dB(A)	dB(A)	dB(A)	m ³ /h	Pa
1	Y	400	50	1400	505	1.15	68	75	75	9120	0
2	Y	400	50	1380	567	1.22	66	72	73	8195	50
3	Y	400	50	1365	623	1.27	64	71	71	7055	100
4	Y	400	50	1350	690	1.35	65	72	72	5480	155

Charts: Air flow 60 Hz

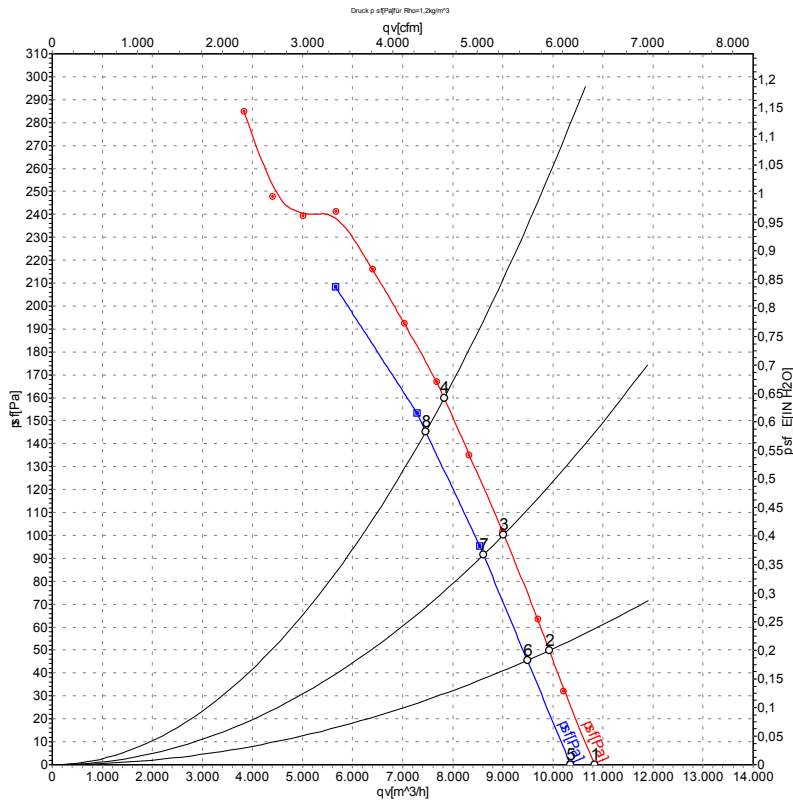

Measurement: LU-110667
Measurement: LU-110708

Air performance measured as per ISO 5801 Installation category A. For detailed information on the measuring set-up, please contact ebm-papst. Suction-side noise levels: LwA measured as per ISO 13347 / LpA measured with 1m distance to fan axis. The values given are valid under the measuring conditions mentioned above and may vary according to the actual installation situation. With any deviation from the standard set-up, the specific values have to be checked and reviewed with the unit installed.

Measured values

	Conn.	U	f	n	P _e	I	LpA _{in}	LwA _{in}	LwA _{out}	qv	p _{sf}
		V	Hz	min ⁻¹	W	A	dB(A)	dB(A)	dB(A)	m³/h	Pa
1	Y	480	60	1650	817	1.33	71	78	79	10830	0
2	Y	480	60	1630	891	1.40	69	77	77	9930	50
3	Y	480	60	1615	960	1.47	68	75	75	9015	100
4	Y	480	60	1590	1050	1.57	67	74	74	7825	160
5	Y	400	60	1590	762	1.32	70	77	78	10350	0
6	Y	400	60	1565	820	1.41	68	76	76	9490	46
7	Y	400	60	1540	879	1.49	67	74	74	8610	92
8	Y	400	60	1510	950	1.60	66	73	73	7460	145