

## Nominal data

Type	R2E140-AE77-05		
Motor	M2E068-BF		
Phase		1~	1~
Nominal voltage	VAC	230	230
Frequency	Hz	50	60
Type of data definition		fa	ml
Valid for approval / standard		CE	CE
Speed	min <sup>-1</sup>	1400	1500
Power input	W	105	115
Current draw	A	0.46	0.51
Motor capacitor	µF	2	2
Capacitor voltage	VDB	450	450
Min. back pressure	Pa	0	50
Min. ambient temperature	°C	-25	-25
Max. ambient temperature	°C	40	35
Starting current	A	0.47	0.48

ml = max. load · me = max. efficiency · fa = running at free air · cs = customer specs · cu = customer unit  
Subject to alterations

### Technical features

<b>Mass</b>	1.18 kg
<b>Size</b>	140 mm
<b>Surface of rotor</b>	Partially cast in aluminium
<b>Material of impeller</b>	Sheet steel, hot-galvanised
<b>Direction of rotation</b>	Clockwise, seen on rotor
<b>Type of protection</b>	IP 44; Depending on installation and position
<b>Insulation class</b>	"B"
<b>Humidity class</b>	F0
<b>Max. permissible ambient motor temp. (transp./ storage)</b>	+ 80 °C
<b>Min. permissible ambient motor temp. (transp./storage)</b>	- 40 °C
<b>Mounting position</b>	Any
<b>Condensate discharge holes</b>	None
<b>Operation mode</b>	S1
<b>Motor bearing</b>	Ball bearing
<b>Touch current acc. IEC 60990 (measuring network Fig. 4, TN system)</b>	< 0.75 mA
<b>Motor protection</b>	Thermal overload protector (TOP) wired internally
<b>Cable exit</b>	Variable
<b>Protection class</b>	I (if protective earth is connected by customer)
<b>Product conforming to standard</b>	EN 60335-1; CE
<b>Approval</b>	GOST; CCC

## Product drawing

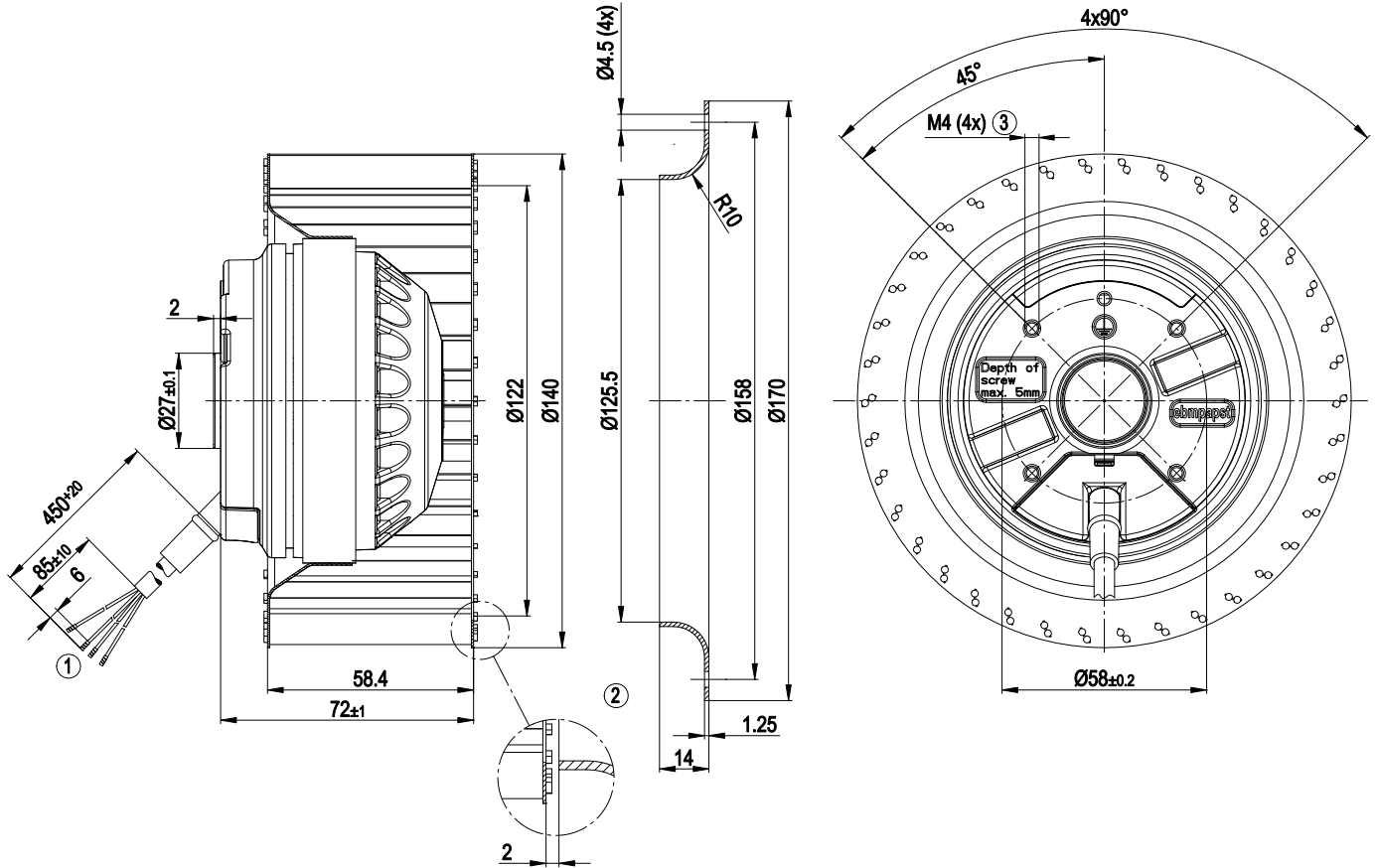

- |   |   |
|---|---|
| 1 | Connection line PVC 4G0.5mm <sup>2</sup> , 4x brass lead tips crimped                     |
| 2 | Accessory part: Inlet nozzle 09576-2-4013, not included in the standard scope of delivery |
| 3 | Depth of screw max. 5 mm  |

## Connection screen

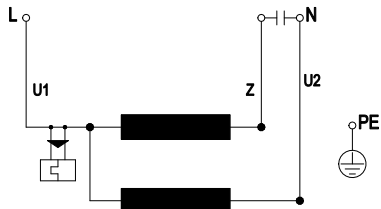

U1	blue	Z	brown	U2	black
PE	green/yellow				

## Charts: Air flow 50 Hz

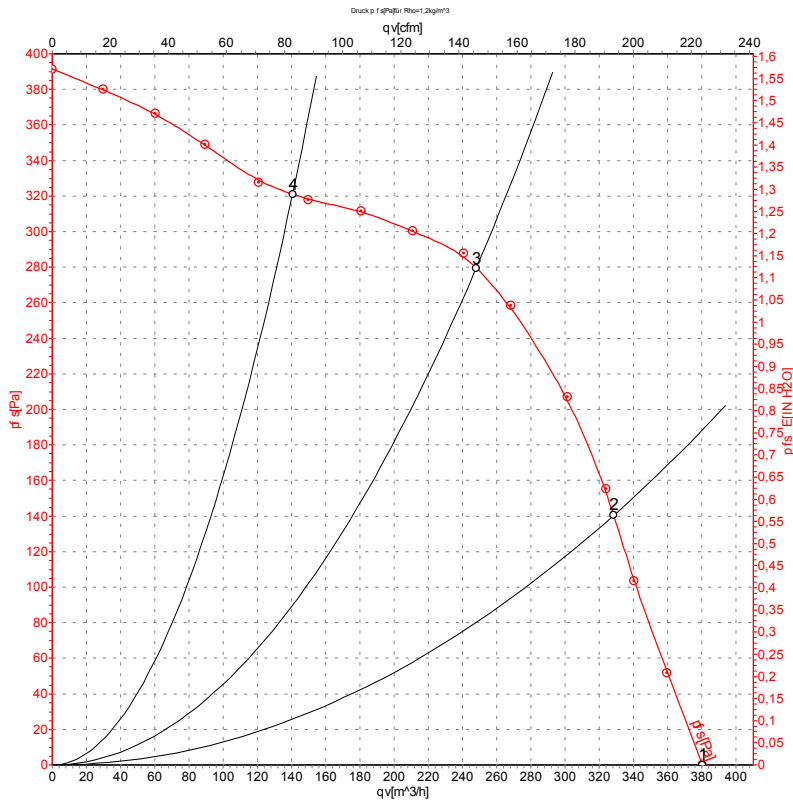

Measurement: LU-79019

Air performance measured as per ISO 5801 Installation category A. For detailed information on the measuring set-up, please contact ebm-papst. Suction-side noise levels: LwA measured as per ISO 13347 / LpA measured with 1m distance to fan axis. The values given are valid under the measuring conditions mentioned above and may vary according to the actual installation situation. With any deviation from the standard set-up, the specific values have to be checked and reviewed with the unit installed.

## Measured values

	U	f	n	P <sub>e</sub>	I	qv	P <sub>fs</sub>
	V	Hz	min <sup>-1</sup>	W	A	m <sup>3</sup> /h	Pa
1	230	50	1400	105	0.46	380	0
2	230	50	1760	94	0.41	330	140
3	230	50	2120	85	0.37	250	280
4	230	50	2445	74	0.33	140	320

U = Supply voltage · f = Frequency · n = Speed · P<sub>e</sub> = Power input · I = Current draw · qv = Air flow · P<sub>fs</sub> = Pressure increase



## Charts: Air flow 60 Hz

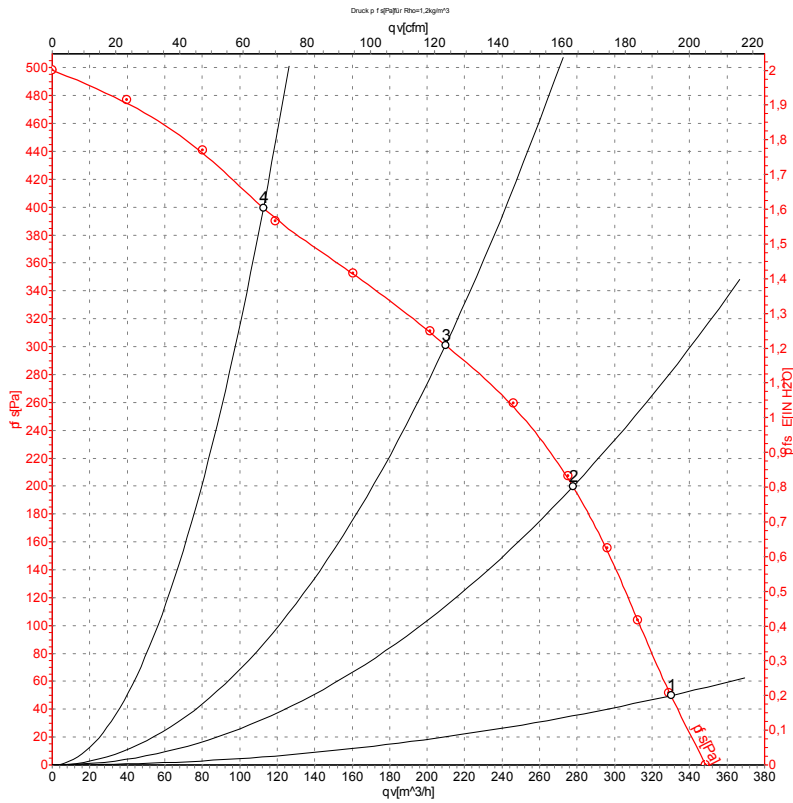

Measurement: LU-79020

Air performance measured as per ISO 5801 Installation category A. For detailed information on the measuring set-up, please contact ebmpapst. Suction-side noise levels: L<sub>wA</sub> measured as per ISO 13347 / L<sub>pA</sub> measured with 1m distance to fan axis. The values given are valid under the measuring conditions mentioned above and may vary according to the actual installation situation. With any deviation from the standard set-up, the specific values have to be checked and reviewed with the unit installed.

## Measured values

	U	f	n	P <sub>e</sub>	I	qv	P <sub>fs</sub>
	V	Hz	min <sup>-1</sup>	W	A	m <sup>3</sup> /h	Pa
1	230	60	1500	115	0.51	330	50
2	230	60	1840	106	0.46	280	200
3	230	60	2300	101	0.44	210	300
4	230	60	2740	91	0.40	115	400

U = Supply voltage · f = Frequency · n = Speed · P<sub>e</sub> = Power input · I = Current draw · qv = Air flow · P<sub>fs</sub> = Pressure increase