

Nominal data

Type	M2E068-CF10-65	
Motor	M2E068-CF	
Phase		1~
Nominal voltage	VAC	230
Frequency	Hz	50
Method of obtaining data		me
Valid for approval/standard		CE
Speed (rpm)	min ⁻¹	2600
Power consumption	W	85
Power output	W	47
Current draw	A	0.38
Rated torque	Ncm	17.4
Mean starting torque	Ncm	11.5
Capacitor	μF	2
Capacitor voltage	VDB	450
Min. ambient temperature	°C	-25
Max. ambient temperature	°C	45
Starting current	A	0.74

ml = Max. load · me = Max. efficiency · fa = Free air · cs = Customer specification · ce = Customer equipment
Subject to change

M2E068-CF10-65

AC motor

Technical description

Fan size	68 mm
Rotor surface	Painted black
Direction of rotation	Clockwise, viewed toward rotor
Degree of protection	IP44; installation- and position-dependent as per EN 60034-5
Insulation class	"B"
Moisture (F) / Environmental (H) protection class	H0+
Max. permitted ambient temp. for motor (transport/storage)	+ 80 °C
Min. permitted ambient temp. for motor (transport/storage)	- 40 °C
Installation position	Shaft horizontal or rotor on top; rotor on bottom on request
Condensation drainage holes	On stator side
Mode	S1
Motor bearing	Ball bearing
Touch current according to IEC 60990 (measuring circuit Fig. 4, TN system)	< 0.75 mA
Motor protection	Thermal overload protector (TOP) internally connected
With cable	Variable
Protection class	I (with customer connection of protective earth)
Conformity with standards	EN 60335-1; CE

Product drawing

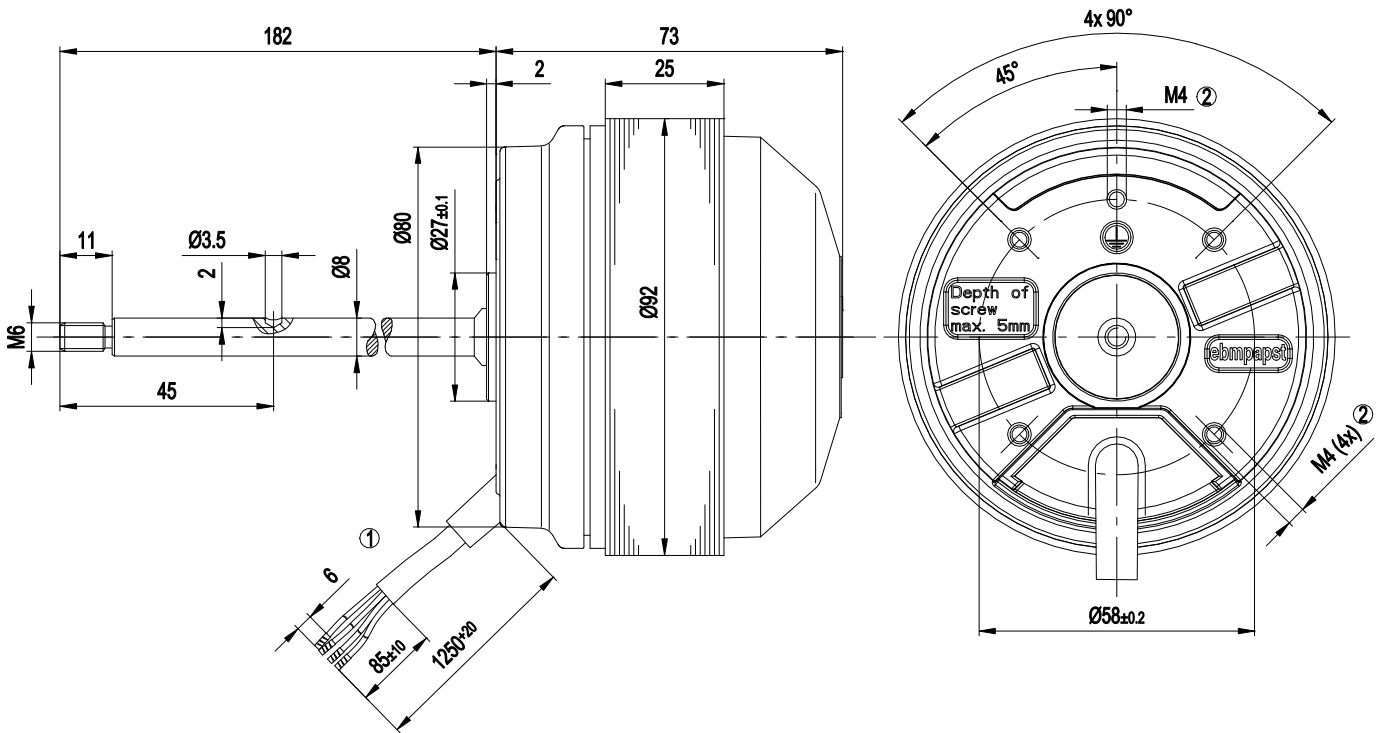

- 1 Cable PVC 4G 0.5 mm², 4x crimped splices
- 2 Max. clearance for screw 5 mm

Connection diagram

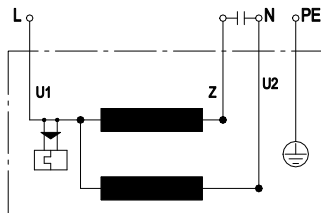

U1	blue	Z	brown	U2	black
PE	green/yellow				

Curves: Speed (rpm)

